

## Dual-Phase COT Buck PWM Controller with Dynamic Voltage Control

### General Description

The RT8811A is a dual-phase synchronous Buck PWM controller which is optimized for high performance graphic microprocessor and computer applications. The IC integrates a Constant-On-Time (COT) PWM controller, two MOSFET drivers with internal bootstrap diodes, as well as channel current balance and protection functions including Over-Voltage Protection (OVP), Under-Voltage Protection (UVP), current limit and thermal shutdown into the WQFN-24L 4x4 package.

The RT8811A adopts  $R_{DS(ON)}$  current sensing technique. Current limit is accomplished through continuous inductor-current-sense, while  $R_{DS(ON)}$  current sensing is used for accurate channel current balance. Using the method of current sampling utilizes the best advantages of each technique.

The RT8811A features external reference input and PWM-VID dynamic output voltage control, in which the feedback voltage is regulated and tracks external input reference voltage. Other features include adjustable switching frequency, dynamic phase number control, internal/external soft-start, power good indicator, and enable functions.

### Features

- Dual-Phase PWM Controller
- Two Embedded MOSFET Drivers and Embedded Switching Boot Diode
- External Reference Input Control
- PWM-VID Dynamic Voltage Control
- Dynamic Phase Number Control
- Lossless  $R_{DS(ON)}$  Current Sensing for Current Balance
- Internal Fixed and External Adjustable Soft-Start
- Built-In 220mA 5V LDO
- Adjustable Current Limit Threshold
- Adjustable Switching Frequency
- UVP/OVP Protection
- Shoot-Through Protection and Short Pulse Free Technology
- Single IC Supply Voltage : 4.5V to 13.2V
- Support an Ultra-Low Output Voltage as Standby Voltage
- Thermal Shutdown
- Thermal Alert Indicator
- Power Good Indicator
- RoHS Compliant and Halogen Free

### Simplified Application Circuit

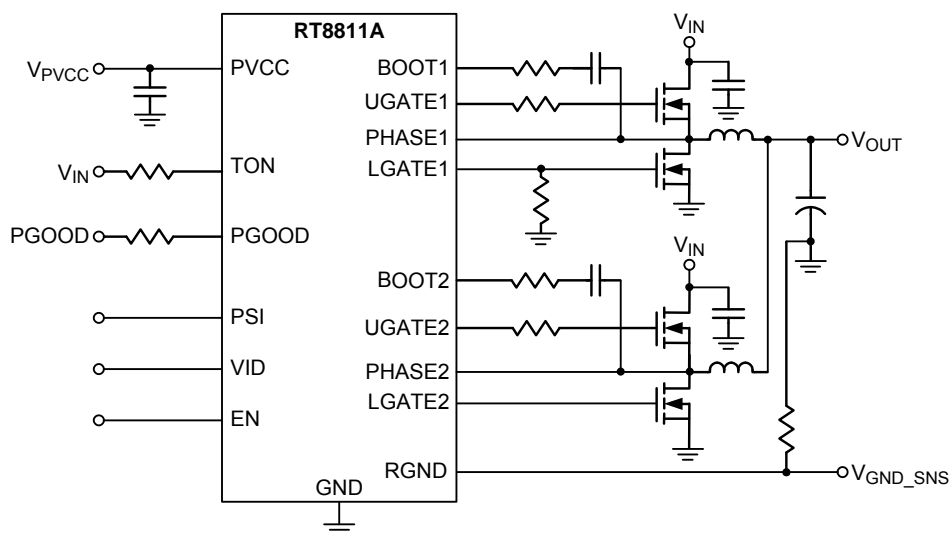

## Applications

- Motherboard to High End GPU Core Power
- High End Desktop PC Memory Core Power
- Low Voltage. High Current DC/DC Converter
- Voltage Regulator Modules

## Marking Information

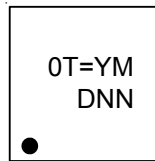

OT= : Product Code  
YMDNN : Date Code

## Ordering Information

RT8811A□□

- Package Type  
QW : WQFN-24L 4x4 (W-Type)  
(Exposed Pad-Option 1)
- Lead Plating System  
G : Green (Halogen Free and Pb Free)

Note :

Richtek products are :

- ▶ RoHS compliant and compatible with the current requirements of IPC/JEDEC J-STD-020.
- ▶ Suitable for use in SnPb or Pb-free soldering processes.

## Pin Configurations

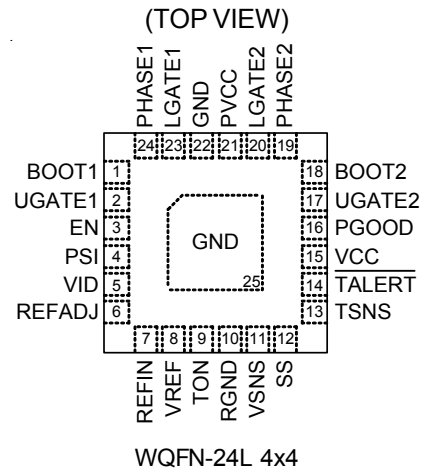

## Function Pin Description

Pin No.	Pin Name	Pin Function
1	BOOT1	Bootstrap Supply for PWM 1. This pin powers the high-side MOSFET driver.
2	UGATE1	High-Side Driver of PWM 1. This pin provides the gate drive for the converter's high-side MOSFET. Connect this pin to the Gate of high-side MOSFET.
3	EN	Enable Control Input. Drive EN higher than 1.6V to turn on the controller, lower than 0.8V to turn it off. If the EN pin is open, it will be pulled to high by internal circuit.
4	PSI	Power Saving Interface. When the voltage is pulled below 0.8V, the device will operate into 1 phase DEM. When the voltage is between 2.4V to 5.5V, the device will operate into 2 phases force CCM.
5	VID	Programming Output Voltage Control Input. Refer to PWM-VID Dynamic Voltage Control.
6	REFADJ	Reference Adjustment Output. Refer to PWM-VID Dynamic Voltage Control.
7	REFIN	External Reference Input.
8	VREF	Reference Voltage Output. This is a high precision voltage reference (2V) from the VREF pin to the RGND pin.
9	TON	ON-Time/Switching Frequency Adjustment Input.
10	RGND	Negative Remote Sense Input. Connect this pin to the ground of output load.
11	VSNS	Positive Remote Sense Input. Connect this pin to the positive terminal of output load.

Pin No.	Pin Name	Pin Function
12	SS	Soft-Start Time Setting. Connect an external capacitor to adjust soft-start time. When the external capacitor is removed, the internal soft-start function will be chose.
13	TSNS	Temperature Sensing Input.
14	$\overline{\text{TALERT}}$	Thermal Alert. Active low open-drain output.
15	VCC	LDO Regulator Output. Connect a minimum 4.7 $\mu$ F ceramic capacitor between this pin and ground.
16	PGOOD	Power Good Indicator Output. Active high open-drain output.
17	UGATE2	High-Side Driver of PWM 2. This pin provides the gate drive for the converter's high-side MOSFET. Connect this pin to the high-side MOSFET.
18	BOOT2	Bootstrap Supply for PWM 2. This pin powers the high-side MOSFET driver.
19	PHASE2	Switch Node for PWM2. Connect this pin to the Source of high-side MOSFET together with the Drain of low-side MOSFET and the inductor.
20	LGATE2	Low-Side Driver of PWM 2. This pin provides the gate drive for the converter's low-side MOSFET. Connect this pin to the low-side MOSFET.
21	PVCC	Supply Voltage Input. Place a high quality bypass capacitor from this pin to GND.
22, 25 (Exposed Pad)	GND	Ground. Must be connected to GND on PCB. The Exposed pad should be soldered to a large PCB and connected to GND for maximum thermal dissipation.
23	LGATE1	Low-Side Driver of PWM 1. This pin provides the gate drive for the converter's low-side MOSFET. Connect this pin to the Gate of low-side MOSFET.
24	PHASE1	Switch Node for PWM1. Connect this pin to the Source of high-side MOSFET together with the Drain of low-side MOSFET and the inductor.

Function Block Diagram

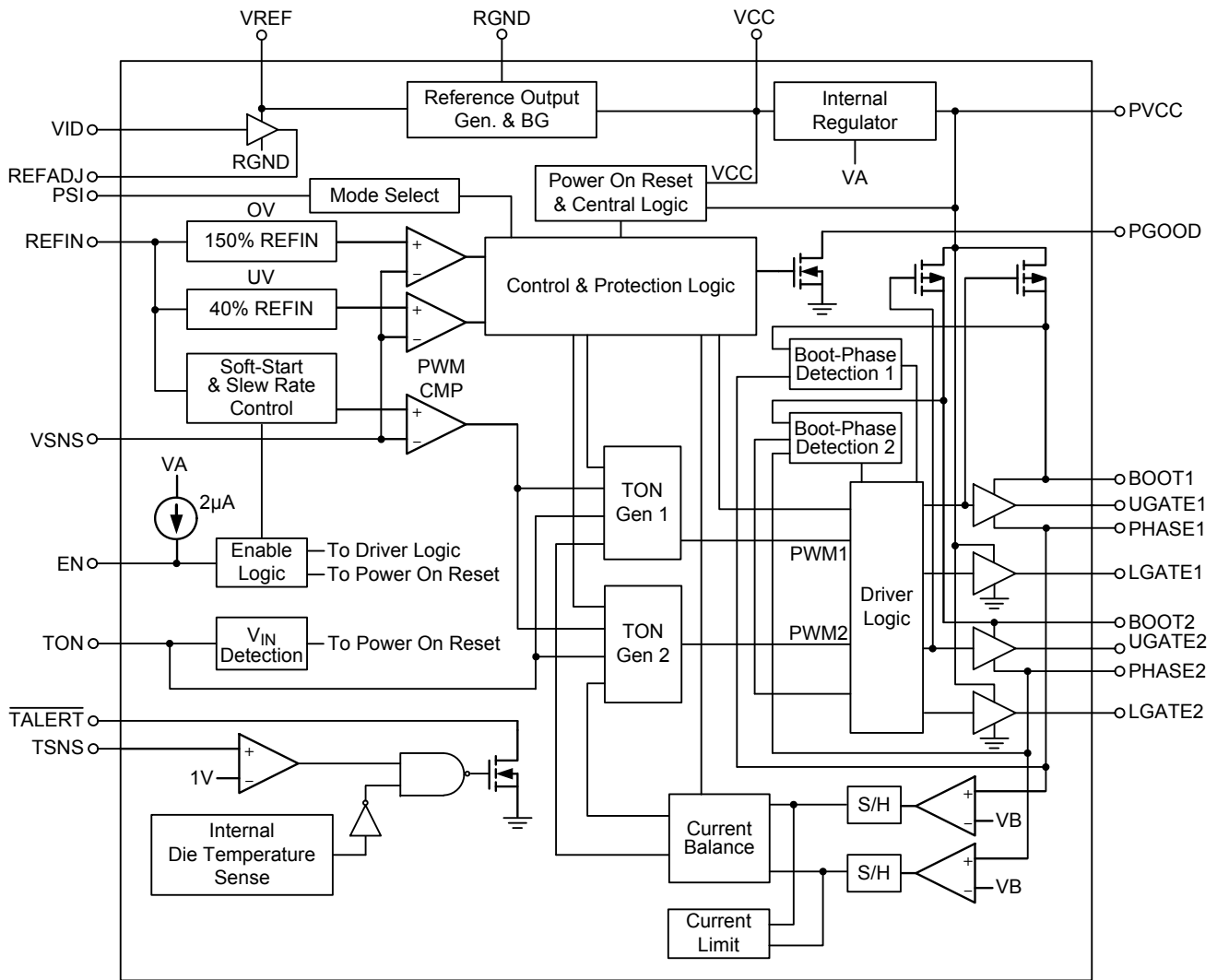

**Operation**

The RT8811A integrates a Constant-On-Time (COT) PWM controller, the controller provides the PWM signal which relies on the output ripple voltage comparing with internal reference voltage. Referring to the function block diagram of TONGenx, the synchronous UGATE driver is turned on at the beginning of each cycle. After the internal one-shot timer expires, the UGATE driver will be turned off. The pulse width of this one-shot is determined by the converter's input voltage and the output voltage to keep the frequency fairly constant over the input voltage and output voltage range. Another one-shot sets a minimum off-time.

The RT8811A also features a PWM-VID dynamic voltage control circuit driven by the pulse width modulation method. This circuit reduces the device pin count and enables a wide dynamic voltage range.

**Current Balance**

The RT8811A implements the internal current balance mechanism in the current loop. The RT8811A senses per phase current and compares it with the average current. If the sensed current of any particular phase is higher than average current, the on-time of this phase will be adjusted to be shorter.

**PGOOD**

The power good output is an open-drain architecture. When the soft-start is finished, the PGOOD open-drain output will be high impedance.

**Soft-Start (SS)**

For internal soft-start function, an internal current source charges an internal capacitor to build the soft-start ramp voltage. The output voltage will track the internal ramp voltage during soft-start interval.

For external soft-start function, an additional capacitor connected from SS to GND will be charged by a current source and determines the soft-start time.

**Current Limit**

The current limit circuit employs a unique "valley" current sensing algorithm. If the magnitude of the current sense signal at PHASE is above the current limit threshold, the PWM is not allowed to initiate a new cycle. Thus, the current to the load exceeds the average output inductor current, the output voltage falls and eventually crosses the under-voltage protection threshold, inducing IC shutdown.

**Over-Voltage Protection (OVP)**

The output voltage can be continuously monitored for over-voltage protection. When the output voltage exceeds its set voltage threshold (If  $V_{REFIN} \leq 1.33V$ ,  $OV = 2V$ , or  $V_{REFIN} > 1.33V$ ,  $OV = 1.5 \times V_{REFIN}$ ), UGATE goes low and LGATE is forced high. The controller is latched until VCC is re-supplied and exceeds the POR rising threshold voltage.

**Under-Voltage Protection (UVP)**

The output voltage is continuously monitored for under-voltage protection. When the output voltage is less than 40% of its set voltage, under-voltage protection is triggered and then both UGATE and LGATE gate drivers are forced low. The controller is latched until VCC is re-supplied and exceeds the POR rising threshold voltage.

## Absolute Maximum Ratings (Note 1)

- TON to GND ----- -0.3 to 32V
- PVCC to GND ----- -0.3 to 15V
- RGND to GND ----- -0.7V to 0.7V
- PHASEx to GND
  - DC ----- -0.3V to 26V
  - <20ns ----- -8V to 38V
- BOOTx to PHASEx ----- 15V
- UGATEx to GND
  - DC ----- 0.3V to (V<sub>BOOT</sub> + 0.3V)
  - <20ns ----- -5V to (V<sub>BOOT</sub> + 5V)
- LGATEx to GND
  - DC ----- -0.3V to (V<sub>PVCC</sub> + 0.3V)
  - <20ns ----- -5V to (V<sub>PVCC</sub> + 5V)
- Other Pins ----- -0.3V to 6V
- Power Dissipation, P<sub>D</sub> @ T<sub>A</sub> = 25°C
  - WQFN-24L 4x4 ----- 3.57W
- Package Thermal Resistance (Note 2)
  - WQFN-24L 4x4, θ<sub>JA</sub> ----- 28°C/W
  - WQFN-24L 4x4, θ<sub>JC</sub> ----- 7°C/W
- Lead Temperature (Soldering, 10 sec.) ----- 260°C
- Junction Temperature ----- 150°C
- Storage Temperature Range ----- -65°C to 150°C
- ESD Susceptibility (Note 3)
  - HBM (Human Body Model) ----- 2kV

## Recommended Operating Conditions (Note 4)

- Supply Input Voltage, V<sub>IN</sub> ----- 7V to 20V
- Control Voltage, V<sub>PVCC</sub> ----- 4.5V to 13.2V
- Junction Temperature Range ----- -40°C to 125°C
- Ambient Temperature Range ----- -40°C to 85°C

## Electrical Characteristics

(T<sub>A</sub> = 25°C unless otherwise specified)

Parameter	Symbol	Test Conditions	Min	Typ	Max	Unit
<b>PWM Controller</b>						
PVCC Supply Voltage	V <sub>PVCC</sub>		4.5	--	13.2	V
PVCC Supply Current	I <sub>SUPPLY</sub>	EN = 3.3V, Not Switching	--	2	4	mA
PVCC Shutdown Current	I <sub>SHDN</sub>	EN = 0V, VCC Remains Active	--	--	220	μA
VCC POR Threshold			3.7	4	4.3	V
POR Hysteresis			--	0.3	--	V
VCC (LDO Output)		PVCC > 10.8V; I <sub>VCC</sub> < 220mA	4.75	5	5.25	V

Parameter	Symbol	Test Conditions	Min	Typ	Max	Unit
VCC Output Current		$V_{CC} = 4.5V$	220	--	400	mA
Switching Frequency		$R_{TON} = 500k\Omega$ (Note 5)	270	300	330	kHz
Minimum $T_{ON}$	$T_{ON(MIN)}$		--	70	--	ns
Minimum Off-Time	$T_{OFF(MIN)}$		--	300	--	ns
Zero Current Crossing Threshold			-8	--	8	mV
<b>EN Threshold</b>						
EN Input Voltage	Logic-High	$V_{ENH}$	1.6	--	--	V
	Logic-Low	$V_{ENL}$	--	--	0.8	
<b>Mode Decision</b>						
PSI High Threshold	$V_{PSIH}$	Enable Two Phases with FCCM	2.4	--	--	V
PSI Low Threshold	$V_{PSIL}$	Enable One Phase with DEM	--	--	0.8	V
VID Input Voltage	Logic-High	$V_{VIDH}$	2	--	--	V
	Logic-Low	$V_{VIDL}$	--	--	1	
<b>Protection Function</b>						
Current Limit Setting Current	$I_{OCSET}$		9	10	11	$\mu A$
Current Limit Setting Current Temperature Coefficient	$I_{OCSET\_TC}$	On the basis of 25°C	--	6300	--	ppm/°C
Current Limit Threshold			-20	--	20	mV
Current Limit Threshold Setting Range			50	--	300	mV
Absolute Over-Voltage Protection Threshold	$V_{OVP, Absolute}$	$V_{REFIN} \leq 1.33V$	1.9	2	2.1	V
Relative Over-Voltage Protection Threshold	$V_{OVP, Relative}$	$V_{REFIN} > 1.33V$	145	150	155	%
OVP Delay	$t_{D\_OVP}$		--	5	--	$\mu s$
Relative Under-Voltage Protection Threshold	$V_{UVP}$	UVP	35	40	45	%
UVP Delay	$t_{D\_UVP}$		--	3	--	$\mu s$
Internal Die Temperature Sense Threshold			--	95	--	°C
Thermal Shutdown Threshold	$T_{SD}$		--	140	--	°C
TSNS Threshold	$V_{TSEN}$	(No Shutting Down)	0.98	1	1.02	V
PGOOD Blanking Time		From EN = High to PGOOD = High with $V_{OUT}$ within Regulation Point	--	3.7	--	ms
$V_{OUT}$ Internal Soft-Start Time	$T_{SS}$	From First UGATE to $V_{OUT}$ Regulation Point, $V_{REFIN} = 1V$ and $V_{OUT}$ Initial = 0V	--	0.7	--	ms
Soft-Start Current Source	$I_{SS}$		--	5	--	$\mu A$

Parameter	Symbol	Test Conditions	Min	Typ	Max	Unit
<b>Error Amplifier</b>						
VSNS Error Comparator Threshold (Valley)		$V_{REFIN} = 1V$	-5	--	5	mV
<b>Reference</b>						
Reference Voltage	$V_{VREF}$	Sourcing Current = 1mA, VID No Switching	1.98	2	2.02	V
<b>Driver On-Resistance</b>						
UGATE Driver Source	$R_{UGATEsr}$	$I_{UGATEx} = 150mA$	--	1.5	3	$\Omega$
UGATE Driver Sink	$R_{UGATEsk}$	$V_{UGATEx} - V_{PHASEx} = 0.1V$	--	2	4	$\Omega$
LGATE Driver Source	$R_{LGATEsr}$	$I_{LGATEx} = 150mA$	--	1.5	3	$\Omega$
LGATE Driver Sink	$R_{LGATEsk}$	$V_{LGATEx} = 0.1V$	--	0.7	1.4	$\Omega$
Dead-Time		From LGATE falling to UGATE rising	--	30	--	ns
		From UGATE falling to LGATE rising	--	30	--	
Boost Switch Ron	$R_{BOOT}$	PVCC to BOOTx, $I_{BOOT} = 10mA$	--	40	80	$\Omega$

**Note 1.** Stresses beyond those listed “Absolute Maximum Ratings” may cause permanent damage to the device. These are stress ratings only, and functional operation of the device at these or any other conditions beyond those indicated in the operational sections of the specifications is not implied. Exposure to absolute maximum rating conditions may affect device reliability.

**Note 2.**  $\theta_{JA}$  is measured at  $T_A = 25^\circ C$  on a high effective thermal conductivity four-layer test board per JEDEC 51-7.  $\theta_{JC}$  is measured at the exposed pad of the package.

**Note 3.** Devices are ESD sensitive. Handling precaution is recommended.

**Note 4.** The device is not guaranteed to function outside its operating conditions.

**Note 5.** Not production tested. Test condition is  $V_{IN} = 8V$ ,  $V_{OUT} = 1V$ ,  $I_{OUT} = 20A$  using application circuit.



Typical Application Circuit

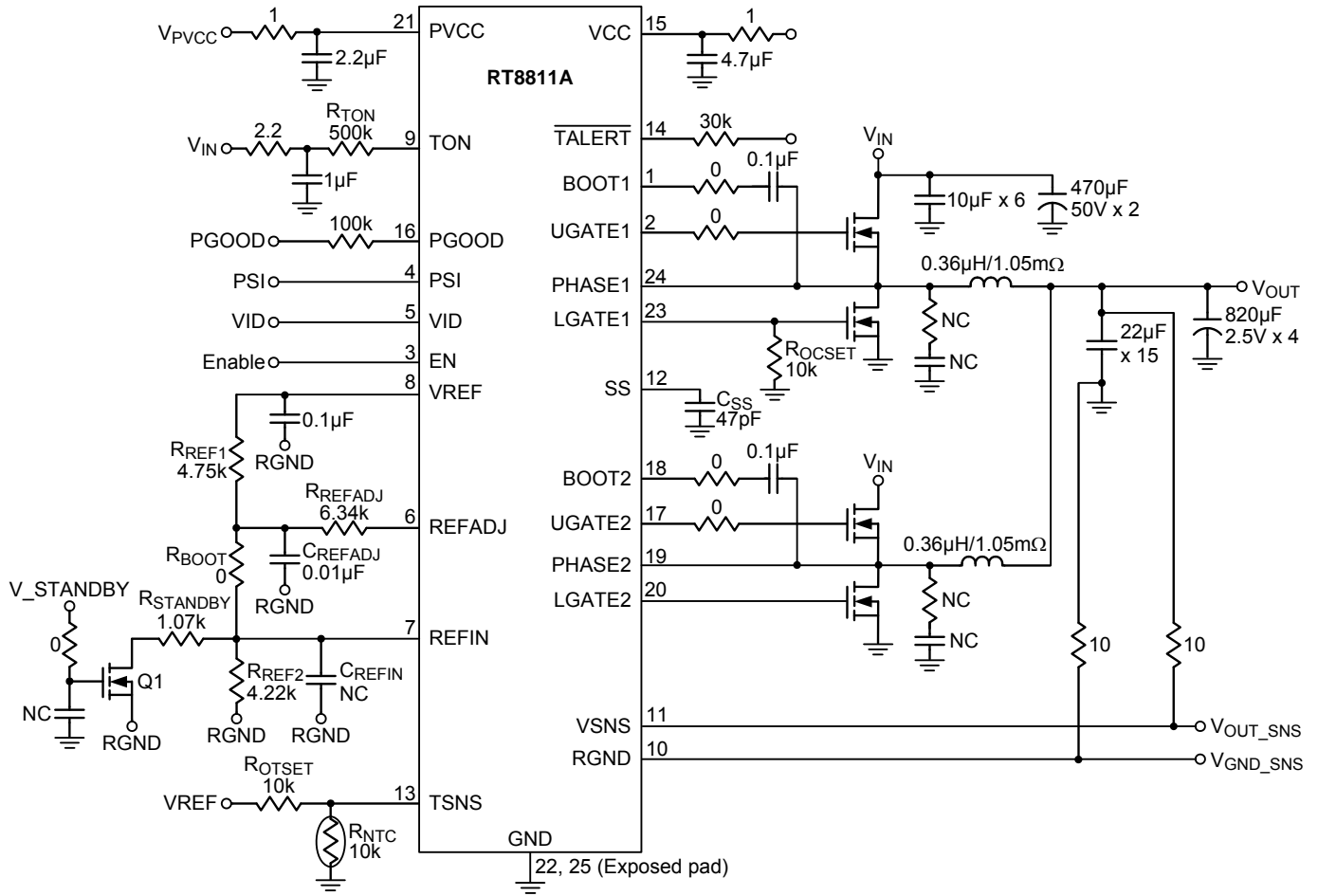

Figure 1. 2 Active Phase Configuration

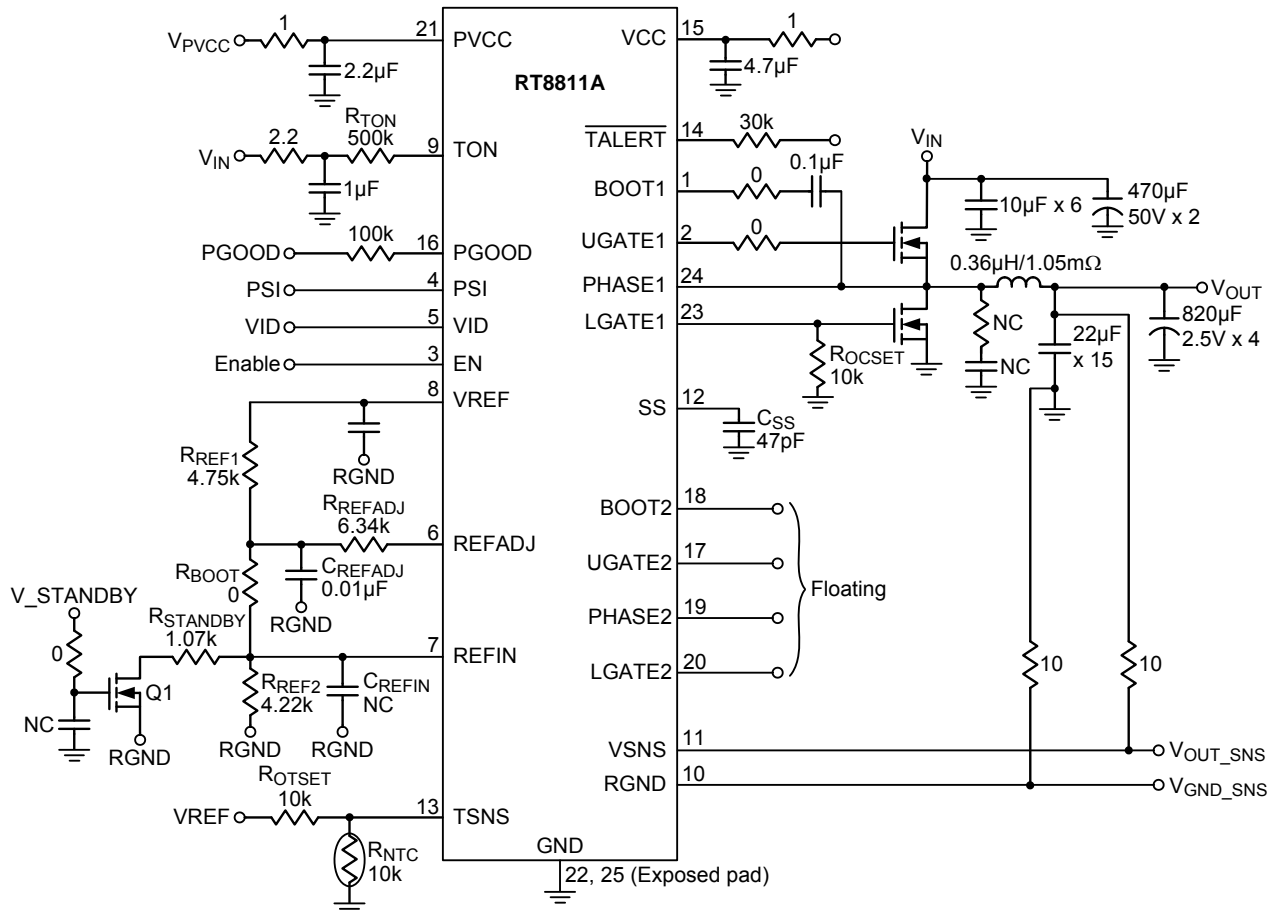
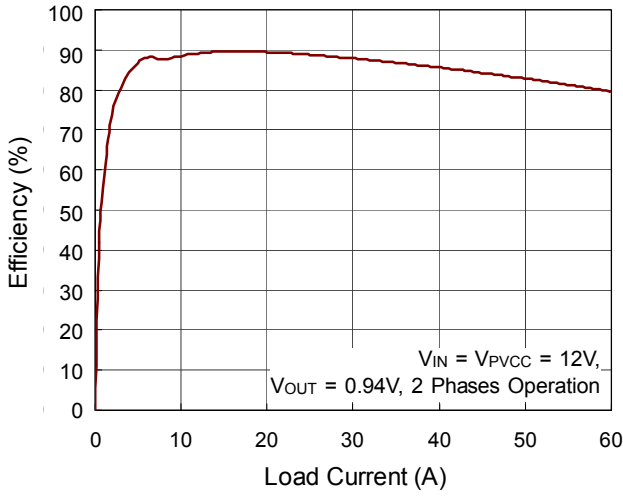

Figure 2. 1 Active Phase Configuration

**Typical Operating Characteristics**

**Efficiency vs. Load Current**



**Efficiency vs. Load Current**

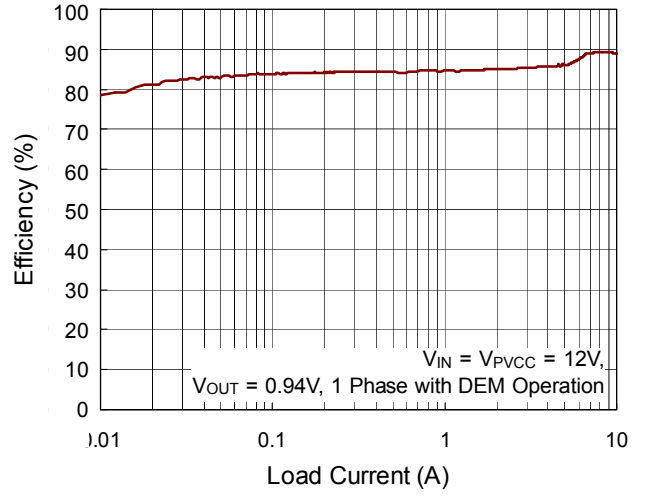

**T<sub>ON</sub> vs. Temperature**

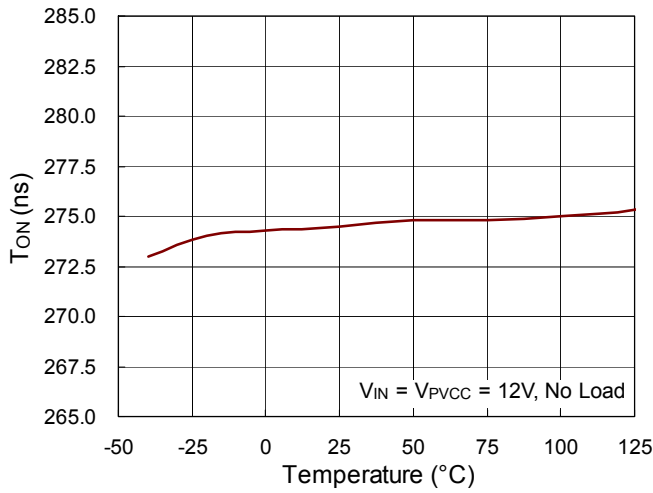

**V<sub>REF</sub> vs. Temperature**

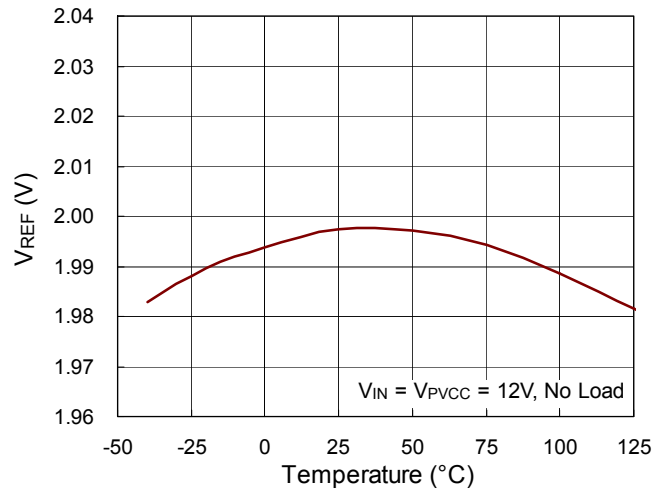

**Inductor Current vs. Output Current**

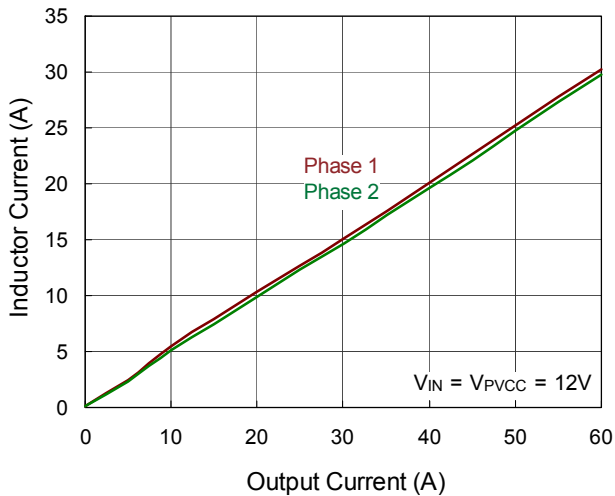

**Power On from EN**

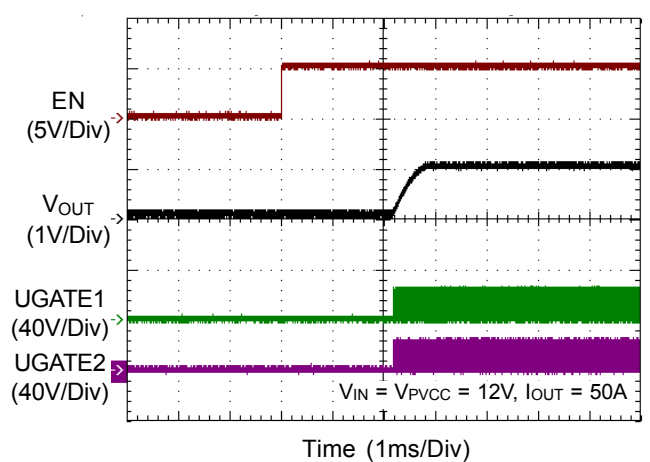

Power Off from EN

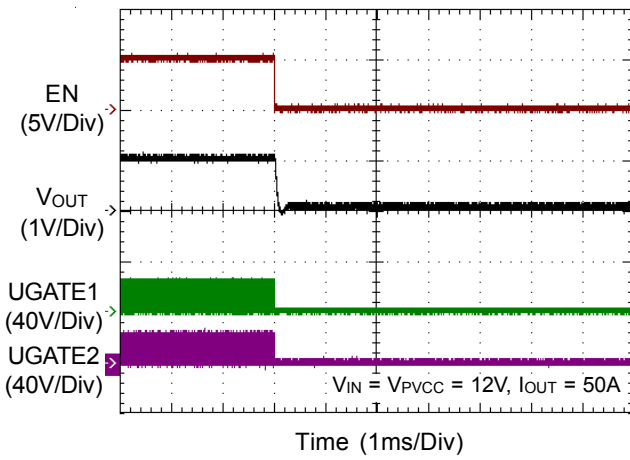

Power On from PVCC

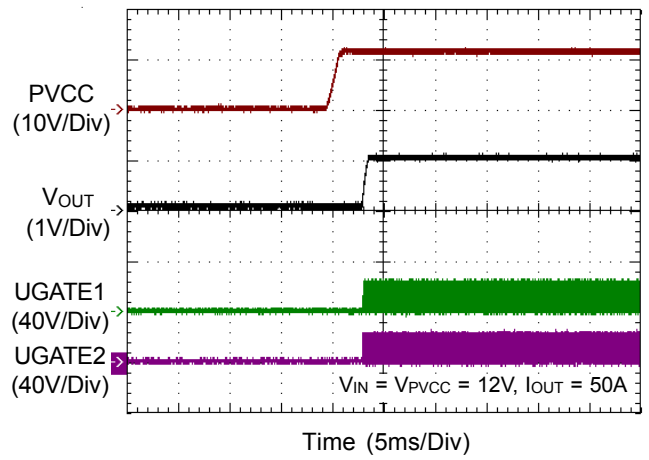

Power Off from PVCC

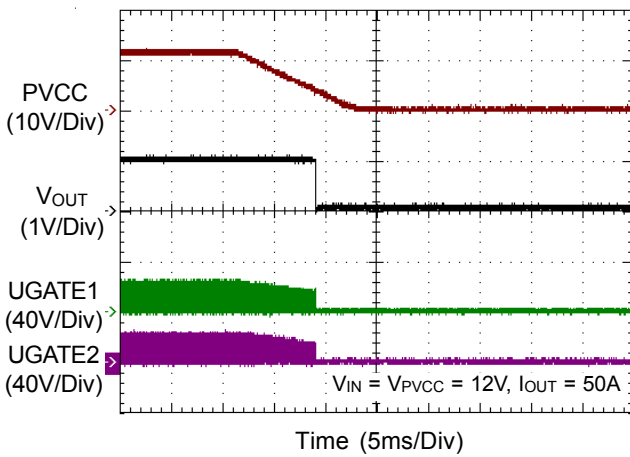

Dynamic Output Voltage Control

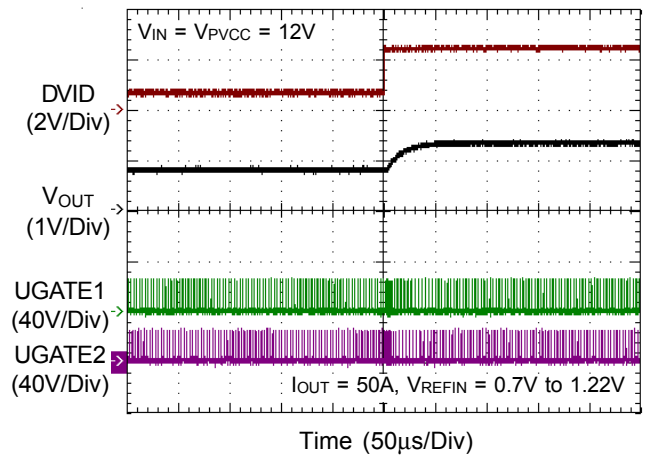

Dynamic Output Voltage Control

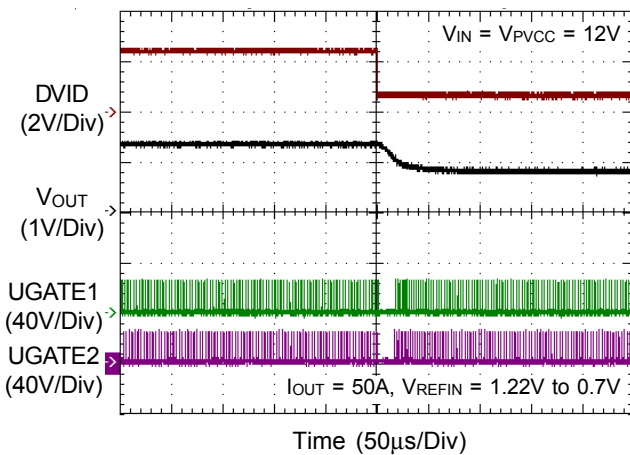

Load Transient Response

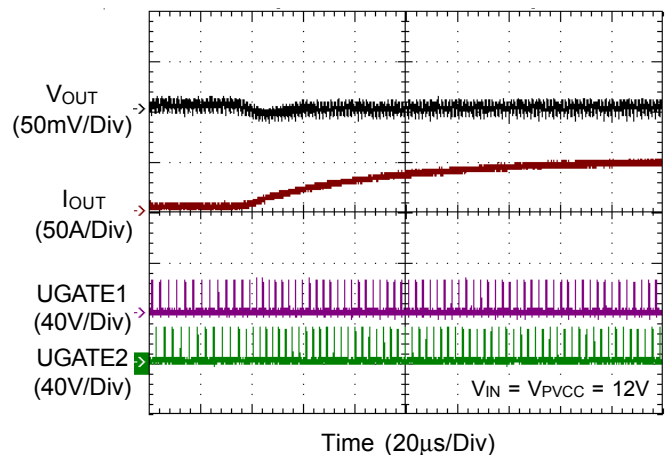

**Load Transient Response**

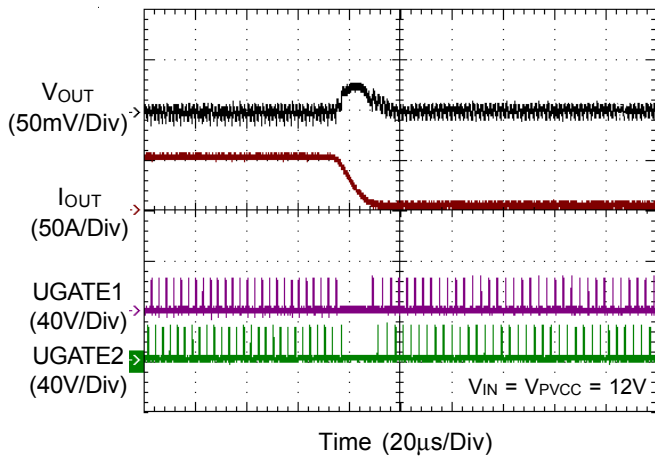

**OVP**

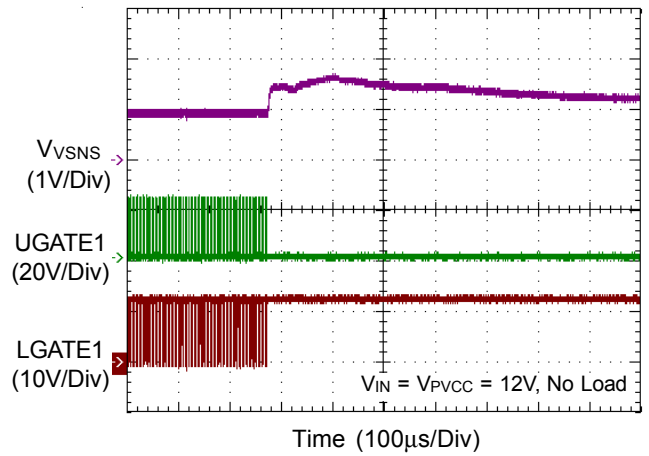

**UVP**

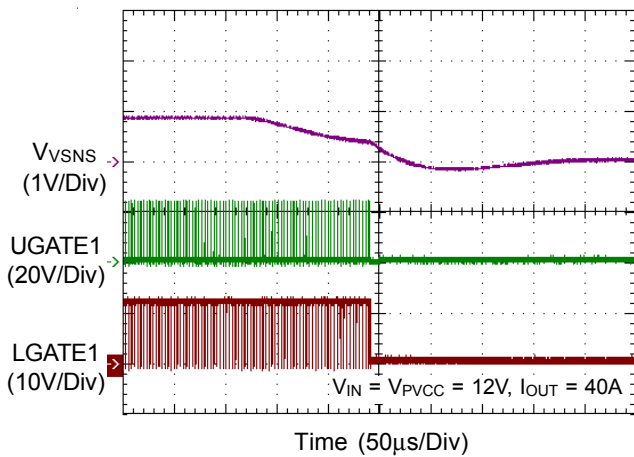

**OCP**

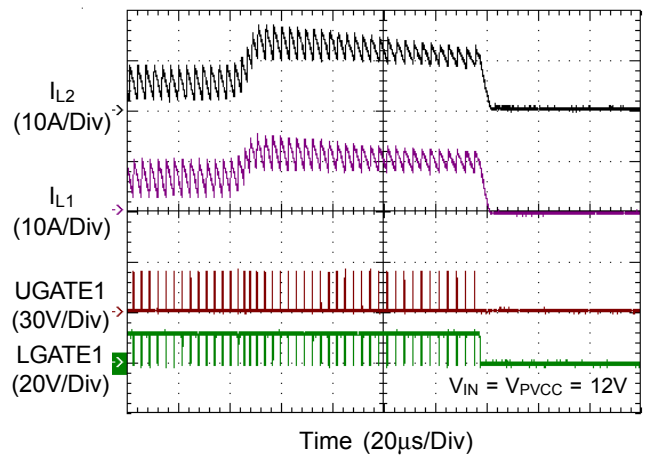

## Application Information

The RT8811A is a dual-phase synchronous Buck PWM controller with integrated drivers which is optimized for high performance graphic microprocessor and computer applications. A COT (Constant-On-Time) PWM controller and two MOSFET drivers with internal bootstrap diodes are integrated so that the external circuit can be easily designed and the number of component is reduced.

The topology solves the poor load transient response timing problems of fixed frequency current mode PWM and avoids the problems caused by widely varying switching frequencies in conventional constant on-time and constant off-time PWM schemes.

The RT8811A supports dynamic mode transition function with various operating states, which include dual-phase with CCM operation, single phase with diode emulation mode. These different operating states make the system efficiency as high as possible.

The RT8811A provides a PWM-VID dynamic control operation in which the feedback voltage is regulated and tracks external input reference voltage. It also features complete fault protection functions including over-voltage, under-voltage and current limit.

### PWM Operation

The RT8811A integrates a Constant-On-Time (COT) PWM controller, and the controller provides the PWM signal which relies on the output ripple voltage comparing with internal reference voltage as shown in Figure 3. Referring to the function block diagram of TON Genx, the synchronous UGATE driver is turned on at the beginning of each cycle. After the internal one-shot timer expires, the UGATE driver will be turned off. The pulse width of this one-shot is determined by the converter's input voltage and the output voltage to keep the frequency fairly constant over the input voltage and output voltage range. Another one-shot sets a minimum off-time.

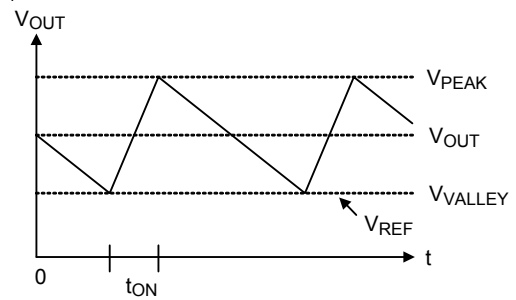

Figure 3. Constant On-Time PWM Control

### Remote Sense

The RT8811A uses the remote sense path (VSNS and RGND) to overcome voltage drops in the power lines by sensing the voltage directly at the end of GPU to make sure the voltage drops on PCB has no impact on the load transient response. Normally, to protect remote sense path disconnecting, there are two resistors ( $R_{Local}$ ) connecting between local sense path and remote sense path. That is, in application with remote sense, the  $R_{Local}$  is recommended to be  $10\Omega$  to  $100\Omega$ . If no need of remote sense, the  $R_{Local}$  is recommended to be  $0\Omega$ .

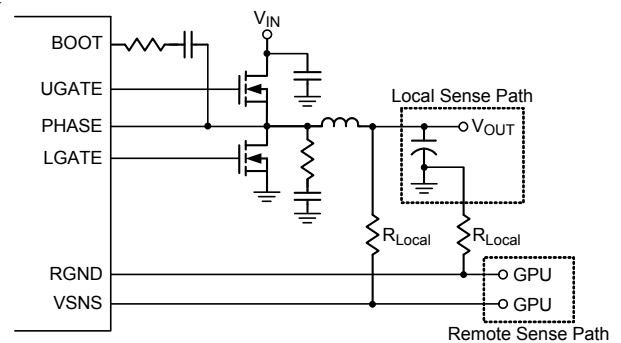

Figure 4. Output Voltage Sensing

### On-Time Control

The on-time one-shot comparator has two inputs. One input monitors the output voltage, the other input samples the input voltage and converts it to a current. This input voltage proportional current is used to charge an internal on-time capacitor. The on-time is the time required for the voltage on this capacitor to charge from zero volts to  $V_{OUT}$ , thereby making the on-time of the high-side switch directly proportional to output voltage and inversely proportional to input voltage. The implementation results in a nearly constant switching frequency without the need for a clock generator.

$$T_{ON} = \frac{2 \times V_{OUT} \times 3.2p}{V_{IN} - 0.5} \times R_{TON}$$

and then the switching frequency  $F_S$  is :

$$F_S = V_{OUT} / (V_{IN} \times T_{ON})$$

$R_{TON}$  is the resistor connected from the  $V_{IN}$  to  $T_{ON}$  pin. The value of  $R_{TON}$  can be selected according to Figure 5. The recommended operation frequency range is 150kHz to 600kHz.

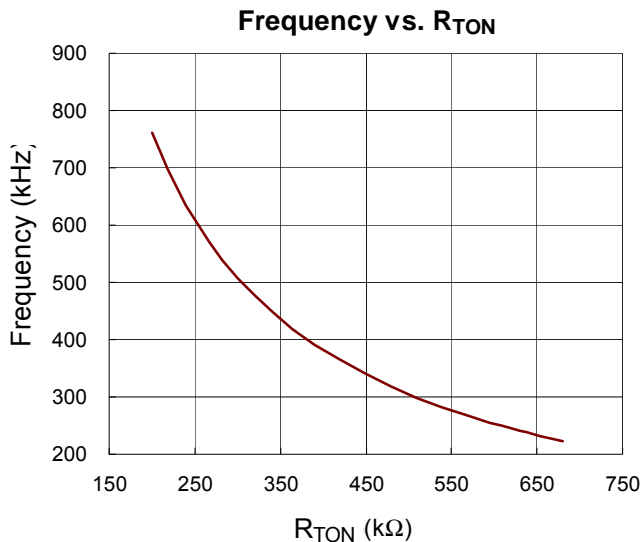

Figure 5. Frequency vs.  $R_{TON}$

**Active Phase Circuit Setting**

The RT8811A can operate in 2/1 phase. For one phase operation, leave the UGATE2, BOOT2, PHASE2, and LGATE 2 as floating, and keep the voltage on the PSI pin under 2.4V before POR.

**Mode Selection**

The RT8811A can operate in 2 phases with force CCM and 1 phase with DEM according to PSI voltage setting. If PSI voltage is pulled below 0.8V, the controller will operate into 1 phase with DEM. In DEM operation, the RT8811A automatically reduces the operation frequency at light load conditions for saving power loss. If PSI voltage is pulled between 2.4V to 5.5V, the controller will switch operation into 2 phases with force CCM. Moreover, the PSI pin is valid after POR of VR.

**Diode-Emulation Mode**

In diode-emulation mode, the RT8811A automatically reduces switching frequency at light-load conditions to maintain high efficiency. As the output current decreases from heavy-load condition, the inductor current is also reduced, and eventually comes to the point that its valley touches zero current, which is the boundary between continuous conduction and discontinuous conduction modes. By emulating the behavior of diodes, the low-side MOSFET allows only partial of negative current when the inductor freewheeling current reaches negative level. As the load current is further decreased, it takes longer and longer to discharge the output capacitor to the level that requires the next "ON" cycle. In reverse, when the output current increases from light load to heavy load, the switching frequency increases to the preset value as the inductor current reaches the continuous condition.

The switching waveforms may appear noisy and asynchronous when light loading causes diode-emulation operation, but this is a normal operating condition that results in high light load efficiency. Trade-off in DEM noise vs. light load efficiency is made by varying the inductor value. Generally, low inductor values produce a broader efficiency vs. load curve, while higher values result in higher full-load efficiency (assuming that the coil resistance remains fixed) and less output voltage ripple. The disadvantages for using higher inductor values include larger physical size and degrade load-transient response (especially at low input voltage levels).

**Forced-CCM Mode**

The low noise, forced-CCM mode disables the zero-crossing comparator, which controls the low-side switch on-time. This causes the low-side gate drive waveform to become the complement of the high-side gate drive waveform. This in turn causes the inductor current to reverse at light loads as the PWM loop to maintain a duty ratio  $V_{OUT} / V_{IN}$ . The benefit of forced-CCM mode is to keep the switching frequency fairly constant.

### Enable and Disable

The EN pin allows power sequencing between the controller bias voltage and another voltage rail. The RT8811A remains in shutdown if the EN pin is lower than 0.8V. When the EN pin rises above 1.6V, the RT8811A will begin a new initialization and soft-start cycle. If the EN pin is open it will be pulled to high by internal circuit.

### Power On Reset (POR), UVLO

Power On Reset (POR) occurs when VCC rises above to approximately 4V (typ.), the RT8811A will reset the fault latch and preparing the PWM for operation. Below 3.7V (typ.), the VCC Under-Voltage Lockout (UVLO) circuitry inhibits switching by keeping UGATE and LGATE low.

### Soft-Start

The RT8811A provides an internal soft-start function and an external soft-start function. The soft-start function is used to prevent large inrush current and output voltage overshoot while the converter is being powered up. The soft-start function automatically begins once the chip is enabled.

If external capacitor from SS to GND is removed, the internal soft-start function will be chosen. An internal current source charges the internal soft-start capacitor such that the internal soft-start voltage ramps up uniformly. The output voltage will track the internal soft-start voltage during the soft-start interval. After the internal soft-start voltage exceeds the REFIN voltage, the output voltage no longer tracks the internal soft-start voltage but follows the REFIN voltage. Therefore, the duty cycle of the UGATE signal as well as the input current at power up are limited. The soft-start process is finished until both the single internal SSOK and external SSOK go high and protection is not triggered. Figure 6 shows the internal soft-start sequence.

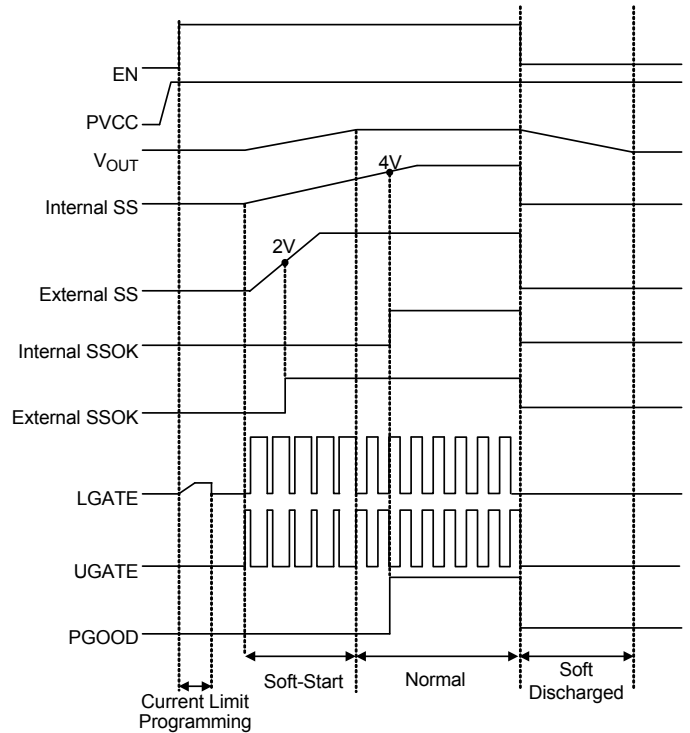

Figure 6. Internal Soft-Start Sequence

The RT8811A also provides a proximate external soft-start function, and the external soft-start sequence is shown in Figure 7, an additional capacitor can be connected from SS to GND. The external capacitor will be charged by 5 $\mu$ A current source to build soft-start voltage ramp. If external soft-start function is chosen, the external soft-start time should be set longer than internal soft-start time to avoid output voltage tracking the internal soft-start ramp, the external soft-start time setting is shown in Figure 8, the recommend external soft-start slew rate is 0.1V/ms to 0.4V/ms.



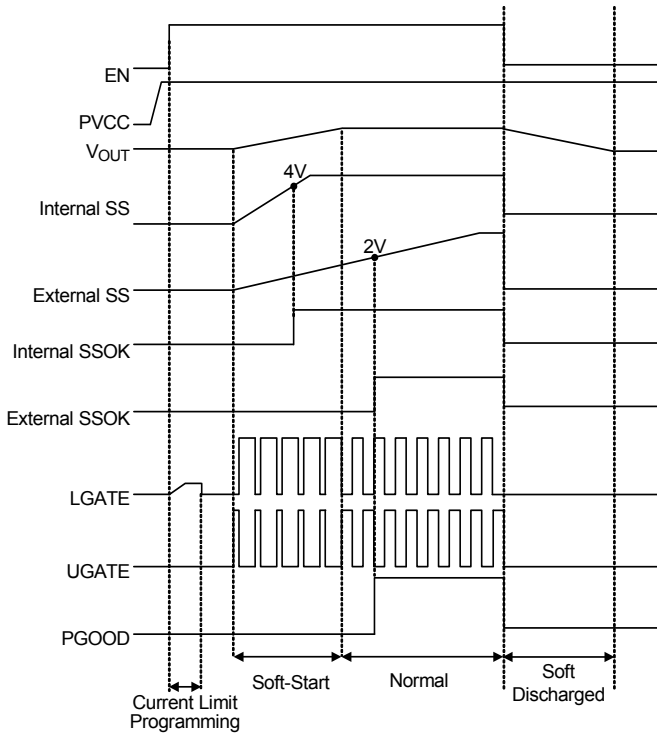

Figure 7. External Soft-Start Sequence

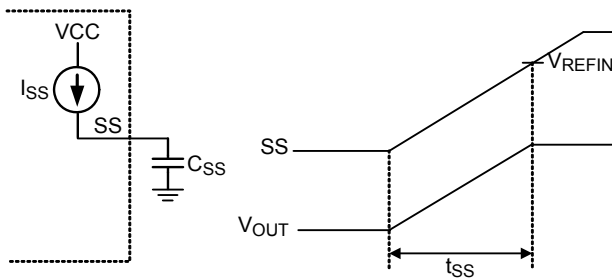

Figure 8. External Soft-Start Time Setting

The soft-start time can be calculated as :

$$t_{SS} = \frac{(C_{SS} \times V_{REFIN})}{I_{SS}}$$

where  $I_{SS} = 5\mu A$  (typ.),  $V_{REFIN}$  is the voltage of REF<sub>IN</sub> pin, and  $C_{SS}$  is the external capacitor placed from SS to GND.

**Power Good Output (PGOOD)**

The power good output is an open-drain architecture, and it requires a pull-up resistor. During soft-start, PGOOD is actively held low and is allowed to be pulled high after  $V_{OUT}$  achieved over UVP threshold, under OVP threshold, and soft start is completed. In addition if any protection is triggered during operation, PGOOD will be pulled low immediately.

**PWM VID and Dynamic Output Voltage Control**

The RT8811A features a PWM VID control as shown in Figure 9, which reduces the number of device pin and enables a wide dynamic voltage range. The output voltage is determined by the applied voltage on the REF<sub>IN</sub> pin. After VCC POR, the buffer output is available, the VID PWM duty cycle determines the variable output voltage at REF<sub>IN</sub>.

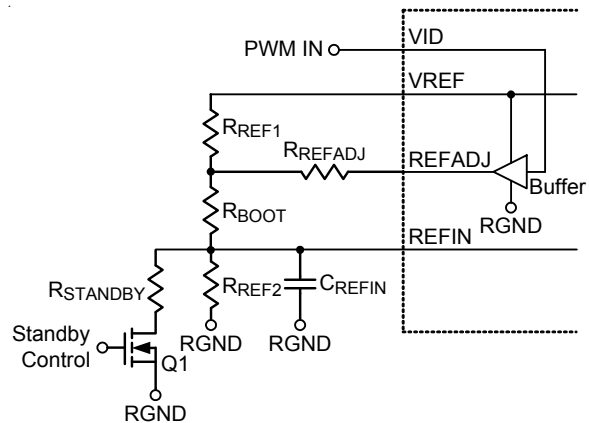

Figure 9. PWM VID Analog Circuit Diagram

According to the PWM VID and external circuit control, the controller can be set three modes which is shown in Figure 10.

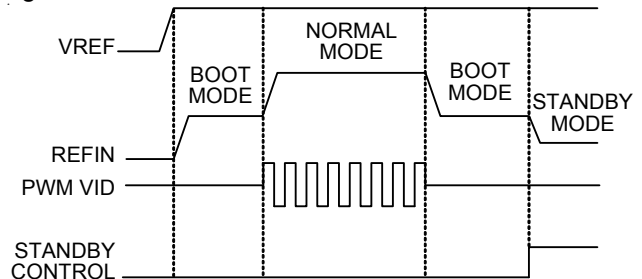

Figure 10. PWM VID Time Diagram

**Boot Mode**

When VID is not driven, and the buffer output is tri-state. At this time, turn off the switch Q1 and connect a resistor divider as shown in Figure 9 that can set the REF<sub>IN</sub> voltage into  $V_{BOOT}$  according to below calculation :

$$V_{BOOT} = V_{VREF} \times \left( \frac{R_{REF2}}{R_{REF1} + R_{REF2} + R_{BOOT}} \right)$$

where  $V_{VREF} = 2V$  (typ.)

Choose  $R_{REF2}$  to be approximately 10kΩ, and the  $R_{REF1}$  and  $R_{BOOT}$  can be calculated by the following equations :

$$R_{REF1} + R_{BOOT} = \frac{R_{REF2} \times (V_{VREF} - V_{BOOT})}{V_{BOOT}}$$

$$R_{REF1} = \frac{R_{REF2} \times (V_{VREF} - V_{BOOT})}{V_{BOOT}} - R_{BOOT}$$

$$R_{BOOT} = \frac{R_{REF2} \times (V_{VREF} - V_{BOOT})}{V_{BOOT}} - R_{REF1}$$

Standby mode. An external control can provide a very low voltage to meet  $V_{OUT}$  going to standby mode, If the VID pin is not driven and switch Q1 is enabled, the REF1 pin can be set for standby voltage according to the calculation below :

$$V_{STANDBY} = V_{VREF} \times \frac{R_{REF2} // R_{STANDBY}}{R_{REF1} + R_{BOOT} + (R_{REF2} // R_{STANDBY})}$$

By choosing  $R_{REF1}$ ,  $R_{REF2}$ , and  $R_{BOOT}$ , the  $R_{STANDBY}$  can be calculated by the following equation :

$$R_{STANDBY} = \frac{R_{REF2} \times (R_{REF1} + R_{BOOT}) \times V_{STANDBY}}{R_{REF2} \times V_{VREF} - V_{STANDBY} \times (R_{REF1} + R_{REF2} + R_{BOOT}) - R_{REF1}}$$

**Normal Mode**

If the VID pin is driven and switch Q1 is disabled, the  $V_{REFIN}$  can be adjusted from  $V_{min}$  to  $V_{max}$ , where  $V_{min}$  is the zero percent duty cycle voltage value and  $V_{max}$  is the one hundred percent duty cycle voltage value.  $V_{min}$  and  $V_{max}$  can be set according to below calculation :

$$V_{min} = V_{VREF} \times \frac{R_{REF2}}{R_{REF2} + R_{BOOT}} \times \frac{R_{REFADJ} // (R_{BOOT} + R_{REF2})}{R_{REF1} + [R_{REFADJ} // (R_{BOOT} + R_{REF2})]}$$

$$V_{max} = V_{VREF} \times \frac{R_{REF2}}{(R_{REF1} // R_{REFADJ}) + R_{BOOT} + R_{REF2}}$$

By choosing  $R_{REF1}$ ,  $R_{REF2}$ , and  $R_{BOOT}$ , the  $R_{REFADJ}$  can be calculated by the following equation :

$$R_{REFADJ} = \frac{R_{REF1} \times V_{min}}{V_{max} - V_{min}}$$

The relationship between VID duty and  $V_{REFIN}$  is shown in Figure 11, and  $V_{OUT}$  can be set according to the calculation below :

$$V_{OUT} = V_{min} + N \times V_{STEP}$$

where  $V_{STEP}$  is the resolution of each voltage step :

$$V_{STEP} = \frac{(V_{max} - V_{min})}{N_{max}}$$

$N_{max}$  is total available voltage step numbers and  $N$  is the number of steps at a specific  $V_{OUT}$ . The dynamic voltage VID period ( $T_{vid} = T_u \times N_{max}$ ) is determined by the unit pulse width ( $T_u$ ) and the available step number ( $N_{max}$ ). The recommend  $T_u$  is 27ns.

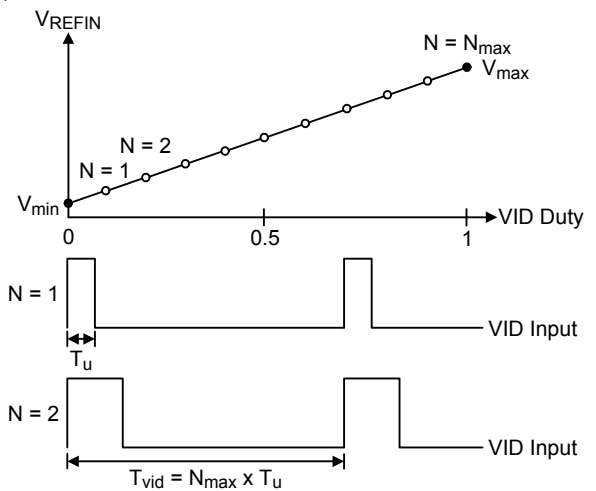

Figure 11. PWM VID Analog Output

**VID Slew Rate Control**

In RT8811A, the  $V_{REFIN}$  slew rate is proportional to PWM VID duty. The rising time and falling time are the same because the voltage of REF1 pin traveling is the same. In normal mode, the  $V_{REFIN}$  slew rate SR can be estimated by  $C_{REFADJ}$  or  $C_{REFIN}$  as the following equation :

When choose  $C_{REFADJ}$  :

$$SR = \frac{(V_{REFIN\_Final} - V_{REFIN\_initial}) \times 80\%}{2.2R_{SR}C_{REFADJ}}$$

$$R_{SR} = [(R_{REF1} // R_{REFADJ}) // (R_{BOOT} + R_{REF2})]$$

When choose  $C_{REFIN}$  :

$$SR = \frac{(V_{REFIN\_Final} - V_{REFIN\_initial}) \times 80\%}{2.2R_{SR}C_{REFIN}}$$

$$R_{SR} = [(R_{REF1} // R_{REFADJ}) + R_{BOOT}] // R_{REF2}$$

The recommend SR is estimated by  $C_{REFADJ}$ .

**Current Balance**

The RT8811A implements internal current balance mechanism in the current loop. The RT8811A senses per phase current signal and compares it with the average current. If the sensed current of any particular phase is higher than average current, the on-time of this phase will be adjusted to be shorter.

**Current Limit**

The RT8811A provides cycle-by-cycle current limit control by detecting the PHASE voltage drop across the low-side MOSFET when it is turned on. The current limit circuit employs a unique “valley” current sensing algorithm. If the magnitude of the current sense signal at PHASE is above the current limit threshold, the PWM is not allowed to initiate a new cycle.

In order to provide both good accuracy and a cost effective solution, the RT8811A supports temperature compensated MOSFET  $R_{DS(ON)}$  sensing.

In an over-current condition, the current to the load exceeds the average output inductor current. Thus, the output voltage falls and eventually crosses the under-voltage protection threshold, inducing IC shutdown.

**Current Limit Setting**

Current limit threshold can be set by a resistor ( $R_{OCSET}$ ) between LGATE1 and GND. Once PVCC exceeds the POR threshold and chip is enabled, an internal current source  $I_{OCSET}$  flows through  $R_{OCSET}$ . The voltage across  $R_{OCSET}$  is stored as the current limit protection threshold  $V_{OCSET}$ . After that, the current source is switched off.

$R_{OCSET}$  can be determined using the following equation :

$$R_{OCSET} = \frac{(I_{VALLEY} \times R_{LGDS(ON)}) + 40mV}{I_{OCSET}}$$

where  $I_{VALLEY}$  represents the desired inductor limit current (valley inductor current) and  $I_{OCSET}$  is current limit setting current which has a temperature coefficient to compensate the temperature dependency of the  $R_{DS(ON)}$ .

If  $R_{OCSET}$  is not present, there is no current path for  $I_{OCSET}$  to build the current limit threshold. In this situation, the current limit threshold is internally preset to 300mV (typ.).

**Negative Current Limit**

The RT8811A supports cycle-by-cycle negative current limit. The value of negative current limit is set as the positive current limit. If negative inductor current is rising to trigger negative current limit, the low-side MOSFET will be turned off and the current will flow to input side through the body diode of the high-side MOSFET. At this time, output voltage tends to rise because this protection limits current to discharge the output capacitor. In order to prevent shutdown because of over-voltage protection, the low-side MOSFET is turned on again 400ns after it is turned off. If the device hits the negative current limit threshold again before output voltage is discharged to the target level, the low-side MOSFET is turned off and process repeats. It ensures maximum allowable discharge capability when output voltage continues to rise. On the other hand, if the output is discharged to the target level before negative current limit threshold is reached, the low-side MOSFET is turned off, the high-side MOSFET is then turned on, and the device resumes normal operation.

**Output Over-Voltage Protection (OVP)**

The output voltage can be continuously monitored for over-voltage protection. If REFIN voltage is lower than 1.33V, the output voltage threshold follows to absolute over-voltage 2V. If REFIN voltage is higher than 1.33V, the output voltage threshold follows relative over-voltage  $1.5 \times V_{REFIN}$ . When OVP is triggered, UGATE goes low and LGATE is forced high. The RT8811A is latched once OVP is triggered and can only be released by PVCC or EN power on reset. A 5µs delay is used in OVP detection circuit to prevent false trigger.

**Output Under-Voltage Protection (UVP)**

The output voltage can be continuously monitored for under-voltage protection. When the output voltage is less than 40% of its set voltage, under-voltage protection is triggered and then all UGATE and LGATE gate drivers are forced low. There is a 3µs delay built into the UVP circuit to prevent false transitions. During soft-start, the UVP blanking time is equal to PGOOD blanking time.

## Thermal Monitoring and Temperature Reporting

The RT8811A provides thermal monitoring function via sensing the TSNS pin voltage, and which can indicate ambient temperature through the voltage divider  $R_{OTSET}$  and  $R_{NTC}$  shown in Figure 12. The voltage of  $V_{TSNS}$  is typically set to be higher than 1V, when ambient temperature rises,  $V_{TSNS}$  will fall, the  $\overline{TALERT}$  signal will be pulled to low level if TSNS voltage drops below 1V or internal die temperature high than 95°C (typ.).

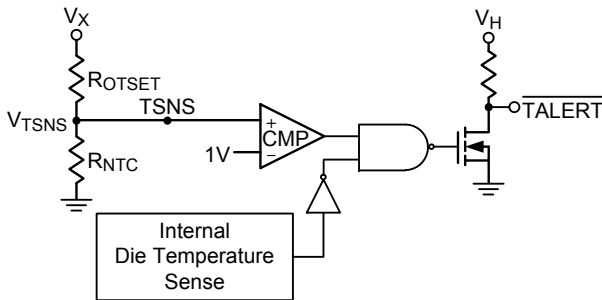

Figure 12. External OTP Setting

$R_{OTSET}$  can be determined using the following equation :

$$R_{OTSET} = R_{NTC,T^{\circ}C} (V_X - 1)$$

where  $R_{NTC,T^{\circ}C}$  is the thermistor's resistance at OTP trigger temperature.

The standard formula for the resistance of the NTC thermistor as a function of temperature is given by :

$$R_{NTC,T^{\circ}C} = R_{25^{\circ}C} \times e^{\left\{ \beta \left[ \left( \frac{1}{T+273} \right) - \left( \frac{1}{298} \right) \right] \right\}}$$

where  $R_{25^{\circ}C}$  is the thermistor's nominal resistance at room temperature 25°C,  $\beta$  (beta) is the thermistor's material constant in Kelvins, and T is the thermistor's actual temperature in Celsius.

## MOSFET Gate Driver

The RT8811A integrates high current gate drivers for the MOSFETs to obtain high efficiency power conversion in synchronous Buck topology. A dead-time is used to prevent the crossover conduction for high-side and low-side MOSFETs. Because both the two gate signals are off during the dead-time, the inductor current freewheels through the body diode of the low-side MOSFET. The freewheeling current and the forward voltage of the body diode contribute to the power loss. The RT8811A employs adaptive dead-time control scheme to ensure safe operation without sacrificing efficiency. Furthermore, elaborate logic

circuit is implemented to prevent cross conduction. For high output current applications, two power MOSFETs are usually paralleled to reduce  $R_{DS(ON)}$ . The gate driver needs to provide more current to switch on/off these paralleled MOSFETs. Gate driver with lower source/sink current capability result in longer rising/falling time in gate signals, and therefore higher switching loss. The RT8811A embeds high current gate drivers to obtain high efficiency power conversion.

## Inductor Selection

Inductor plays an importance role in step-down converters because the energy from the input power rail is stored in it and then released to the load. From the viewpoint of efficiency, the DC Resistance (DCR) of inductor should be as small as possible to minimize the copper loss. In addition, because inductor occupies most of the board space, the size of it is also important. Low profile inductors can save board space especially when the height has limitation. However, low DCR and low profile inductors are usually not cost effective.

Additionally, larger inductance results in lower ripple current, which means the lower power loss. However, the inductor current rising time increases with inductance value. This means the transient response will be slower. Therefore, the inductor design is a trade-off between performance, size and cost.

In general, inductance is designed to let the ripple current ranges between 20% to 40% of full load current. The inductance can be calculated using the following equation :

$$L_{min} = \frac{V_{IN} - V_{OUT}}{F_{SW} \times k \times I_{OUT\_rated}} \times \frac{V_{OUT}}{V_{IN}}$$

where k is the ratio between inductor ripple current and rated output current.

## Input Capacitor Selection

Voltage rating and current rating are the key parameters in selecting input capacitor. Generally, input capacitor has a voltage rating 1.5 times greater than the maximum input voltage is a conservatively safe design.

The input capacitor is used to supply the input RMS current, which can be approximately calculated using the following equation :

$$I_{RMS} = I_{OUT} \times \sqrt{\frac{V_{OUT}}{V_{IN}} \times \left(1 - \frac{V_{OUT}}{V_{IN}}\right)}$$

The next step is to select proper capacitor for RMS current rating. Use more than one capacitor with low Equivalent Series Resistance (ESR) in parallel to form a capacitor bank is a good design. Besides, placing ceramic capacitor close to the Drain of the high-side MOSFET is helpful in reducing the input voltage ripple at heavy load.

**Output Capacitor Selection**

The output filter capacitor must have ESR low enough to meet output ripple and load transient requirement, yet have high enough ESR to satisfy stability requirements. Also, the capacitance must be high enough to absorb the inductor energy going from a full load to no load condition without tripping the OVP circuit. Organic semiconductor capacitor(s) or special polymer capacitor(s) are recommended.

**MOSFET Selection**

The majority of power loss in the step-down power conversion is due to the loss in the power MOSFETs. For low voltage high current applications, the duty cycle of the high-side MOSFET is small. Therefore, the switching loss of the high-side MOSFET is of concern. Power MOSFETs with lower total gate charge are preferred in such kind of application.

However, the small duty cycle means the low-side MOSFET is on for most of the switching cycle. Therefore, the conduction loss tends to dominate the total power loss of the converter. To improve the overall efficiency, the MOSFETs with low  $R_{DS(ON)}$  are preferred in the circuit design. In some cases, more than one MOSFET are connected in parallel to further decrease the on-state resistance. However, this depends on the low-side MOSFET driver capability and the budget.

**Thermal Considerations**

For continuous operation, do not exceed absolute maximum junction temperature. The maximum power dissipation depends on the thermal resistance of the IC package, PCB layout, rate of surrounding airflow, and difference between junction and ambient temperature. The maximum power dissipation can be calculated by the following formula :

$$P_{D(MAX)} = (T_{J(MAX)} - T_A) / \theta_{JA}$$

where  $T_{J(MAX)}$  is the maximum junction temperature,  $T_A$  is the ambient temperature, and  $\theta_{JA}$  is the junction to ambient thermal resistance.

For recommended operating condition specifications, the maximum junction temperature is 125°C. The junction to ambient thermal resistance,  $\theta_{JA}$ , is layout dependent. For WQFN-24L 4x4 package, the thermal resistance,  $\theta_{JA}$ , is 28°C/W on a standard JEDEC 51-7 four-layer thermal test board. The maximum power dissipation at  $T_A = 25^\circ\text{C}$  can be calculated by the following formula :

$$P_{D(MAX)} = (125^\circ\text{C} - 25^\circ\text{C}) / (28^\circ\text{C/W}) = 3.57\text{W for WQFN-24L 4x4 package}$$

The maximum power dissipation depends on the operating ambient temperature for fixed  $T_{J(MAX)}$  and thermal resistance,  $\theta_{JA}$ . The derating curve in Figure 13 allows the designer to see the effect of rising ambient temperature on the maximum power dissipation.

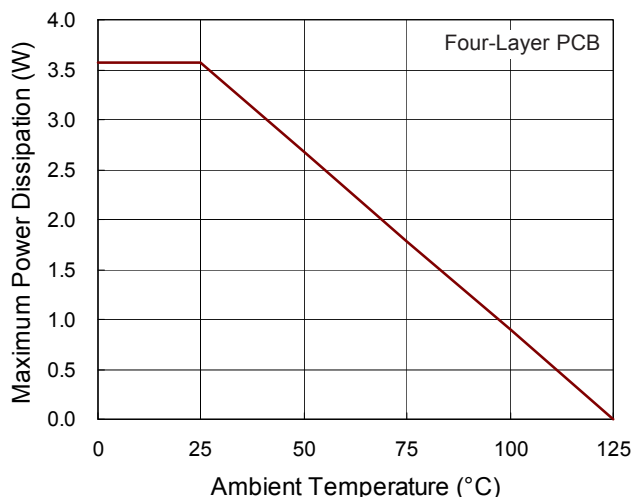

Figure 13. Derating Curve of Maximum Power Dissipation

## Layout Considerations

Layout is very important in high frequency switching converter design. If designed improperly, the PCB could radiate excessive noise and contribute to the converter instability. Certain points must be considered before starting a layout for the RT8811A.

- ▶ Place the RC filter as close as possible to the PVCC pin.
- ▶ Keep current limit setting network as close as possible to the IC. Routing of the network should avoid coupling to high voltage switching node.
- ▶ Connections from the drivers to the respective gate of the high-side or the low-side MOSFET should be as short as possible to reduce stray inductance.
- ▶ All sensitive analog traces and components such as VSNS, RGND, EN, PSI, VID, PGOOD, VREF, VREFADJ, VREFIN and TSNS should be placed away from high voltage switching nodes such as PHASE, LGATE, UGATE, or BOOT nodes to avoid coupling. Use internal layer(s) as ground plane(s) and shield the feedback trace from power traces and components.
- ▶ Power sections should connect directly to ground plane(s) using multiple vias as required for current handling (including the chip power ground connections). Power components should be placed to minimize loops and reduce losses.



**Outline Dimension**

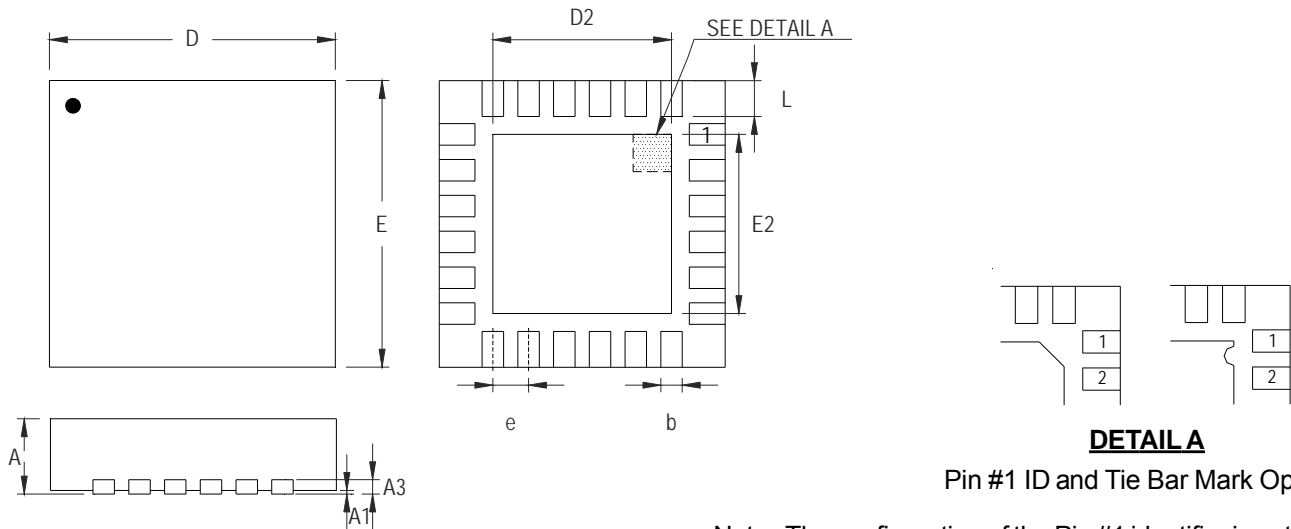

**DETAIL A**

Pin #1 ID and Tie Bar Mark Options

Note : The configuration of the Pin #1 identifier is optional, but must be located within the zone indicated.

Symbol	Dimensions In Millimeters		Dimensions In Inches		
	Min	Max	Min	Max	
A	0.700	0.800	0.028	0.031	
A1	0.000	0.050	0.000	0.002	
A3	0.175	0.250	0.007	0.010	
b	0.180	0.300	0.007	0.012	
D	3.950	4.050	0.156	0.159	
D2	Option 1	2.400	2.500	0.094	0.098
	Option 2	2.650	2.750	0.104	0.108
E	3.950	4.050	0.156	0.159	
E2	Option 1	2.400	2.500	0.094	0.098
	Option 2	2.650	2.750	0.104	0.108
e	0.500		0.020		
L	0.350	0.450	0.014	0.018	

**W-Type 24L QFN 4x4 Package**

**Richtek Technology Corporation**

14F, No. 8, Tai Yuen 1<sup>st</sup> Street, Chupei City  
 Hsinchu, Taiwan, R.O.C.  
 Tel: (8863)5526789

Richtek products are sold by description only. Richtek reserves the right to change the circuitry and/or specifications without notice at any time. Customers should obtain the latest relevant information and data sheets before placing orders and should verify that such information is current and complete. Richtek cannot assume responsibility for use of any circuitry other than circuitry entirely embodied in a Richtek product. Information furnished by Richtek is believed to be accurate and reliable. However, no responsibility is assumed by Richtek or its subsidiaries for its use; nor for any infringements of patents or other rights of third parties which may result from its use. No license is granted by implication or otherwise under any patent or patent rights of Richtek or its subsidiaries.